



SPECIFICATION SHEET

Item Code: **JN-LED/G2**
Description: **JUNGLE G2 LED 240 Watt**

⚡ 100-277V	
PPF	624 μmol/s
LED Efficacy	up to 2.6 μmol/j
Input Power	240W
Input Voltage	100-277V
	Optional 208-480V
Frequency	50/60 Hz
Dimming	0-10V
Light Distribution	120°
Power Factor	>0.9
Rated Lifetime	>50,000 Hours
Dimensions (in)	47.5" x 24.1" x 2.9"
Max Ambient Temperature	100°F / 40°C
Weight (Incl. Driver)	15.0 lbs
Certification Standard	UL8800, UL 1598
	Wet Location, IP65 & CE

Max Amperage by Voltage Service

Voltage	120V	208V	240V	277V	347V	480V
Amperage	2.0A	1.15A	1.0A	0.87A	0.69A	0.5A

Plug Type

- NEMA 5-15P AC Power Cord
- NEMA 6-15P AC Power Cord*
- Power Cord Adapter (120V/240V)
- Power Cord with Lead Wire (Pigtail)*

Extension Cord

- 10 feet AC Power Cord
- 15 feet AC Power Cord*

* Optional hardware/accessory

Accessories

- V Hanger (2)
- 1.5 feet Push-lock Daisy Chain Cable
 - 120V: up to 3 fixtures (daisy chain)
 - 240V: up to 6 fixtures (daisy chain)
 - 277V: up to 7 fixtures (daisy chain)

Product Highlights

- Full-cycle Spectrum LED
- External Control Connectivity
- Energy Efficient (40% less energy than HPS lamps)
- Corrosion Resistance
- Daisy Chain Capability
- IP 65, UL 1598 Wet Location
- Surge Protection
- Warranty: 3-Year Standard, 5-Year Limited

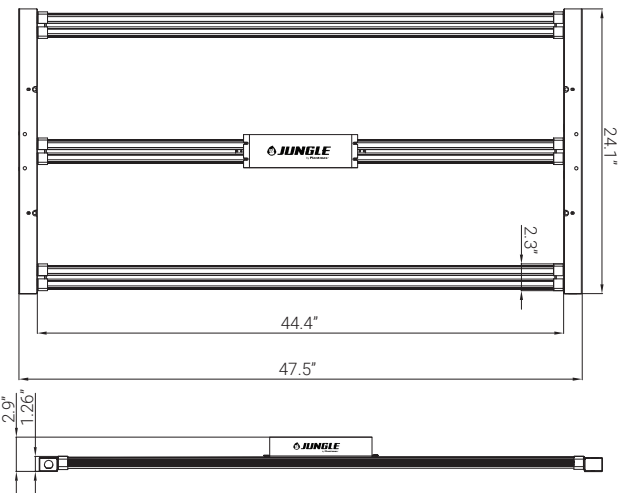
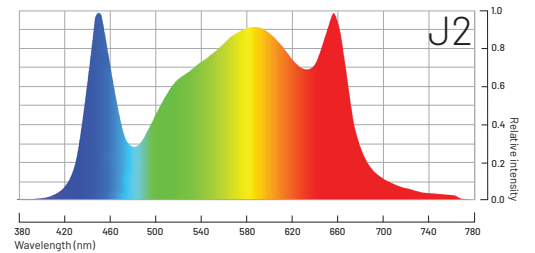
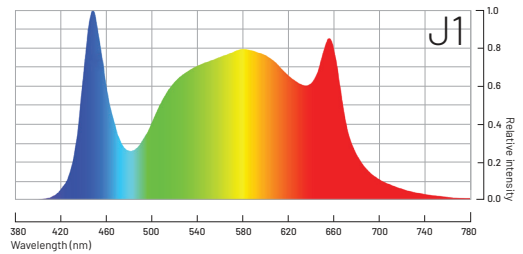

Designed in California, USA. Plantmax® and Jungle® are a registered trademark of Allstate Garden Supply, Inc. Specification subject to change without notice.